

4

3

2

1

REVISION HISTORY					
ECO	ZONE	REV	DESCRIPTION	DATE	APPROVED
		A.01			

NOTES UNLESS OTHERWISE SPECIFIED:

- DRAWING IS FOR REFERANCE ONLY, FOR SPECIFIC DIMENSIONS REFER TO THE MODEL.

B

B

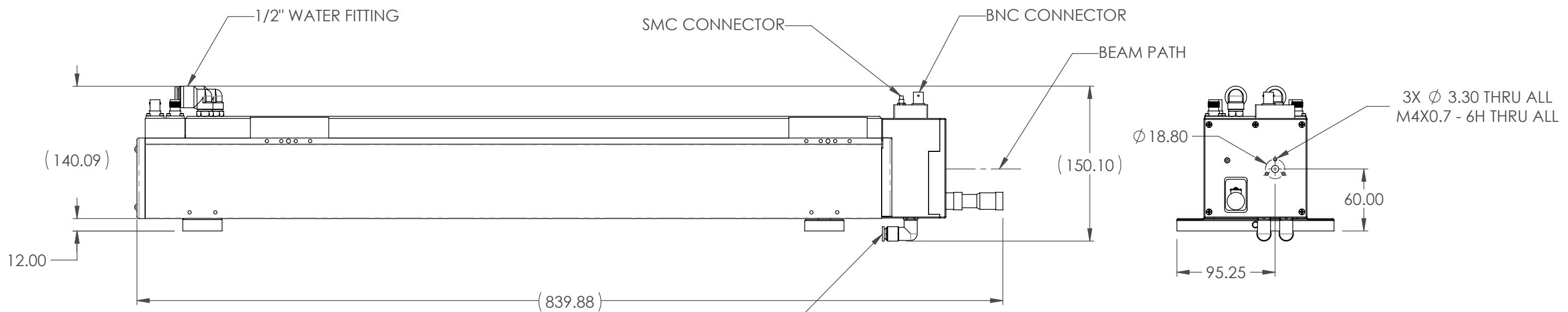

A

A

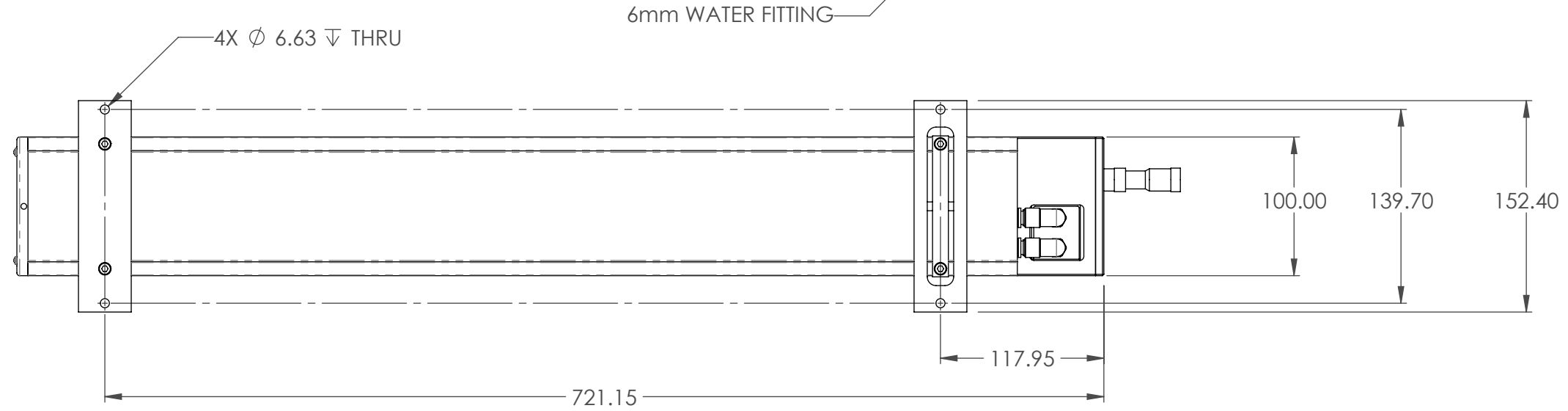

ACCESS LASER TRUMPF
Member of the TRUMPF Group

Phone: 425-582-8674
Fax: 425-582-8679
www.accesslaser.com/
purchasing@accesslaser.com

PROPRIETARY AND CONFIDENTIAL

THE INFORMATION CONTAINED IN THIS DRAWING IS THE SOLE PROPERTY OF ACCESS LASER COMPANY. ANY REPRODUCTION IN PART OR AS A WHOLE WITHOUT THE WRITTEN PERMISSION OF ACCESS LASER COMPANY IS PROHIBITED.

TOLERANCE / UNIT	
ISO 2768	ASME Y14.5-2009
METRIC	INCHES
0.5 UP TO 6 : ±0.1	.x ± .1
< 6 UP TO 30 : ±0.2	.xx ± .01
< 30 UP TO 120 : ±0.3	.xxx ± .005
< 120 UP TO 400 : ±0.5	
< 400 UP TO 1000 : ±0.8	
FRACTIONAL ±1/64	
BEND: ± .3	
ANGULAR: MACH ±0°20'	ANGULAR: MACH ±0°5'

DRAWN BY	
CHECKED BY	
APPROVED BY	
FINISH	
MATERIAL	

THIRD ANGLE PROJECTION	
SURFACE FINISH	

PART NO.		REV	A.01
DESCRIPTION:	AL50GQ LASER, WC 28V		
DRAWING SHALL BE IN ACCORDANCE WITH ASME Y14.5-2009		DO NOT SCALE DRAWING	SCALE 1:20
		SHEET 1 OF 1	SIZE B

4

3

2

1